INTRODUCTION

HOW TO USE THIS MANUAL

INDEX

An INDEX is provided on the first page of each section to guide you to the item to be repaired. To assist you in finding your way through the manual, the Section Title and major heading are given at the top of every page.

GENERAL DESCRIPTION

At the beginning of each section, a general Description is given that pertains to all repair operations contained in that section.

Read these precautions before starting any repair task.

TROUBLESHOOTING

TROUBLESHOOTING tables are included for each system to help you diagnose the problem and find the cause. The fundamentals of how to proceed with troubleshooting are described on page IN-19. Be sure to read this before performing troubleshooting.

PREPARATION

Preparation lists the SST (Special Service Tools), recommended tools, equipment, lubricant and SSM (Special Service Materials) which should be prepared before beginning the operation and explains the purpose of each one.

REPAIR PROCEDURES

Most repair operations begin with an overview illustration. It identifies the components and shows how the parts fit together.

Example:

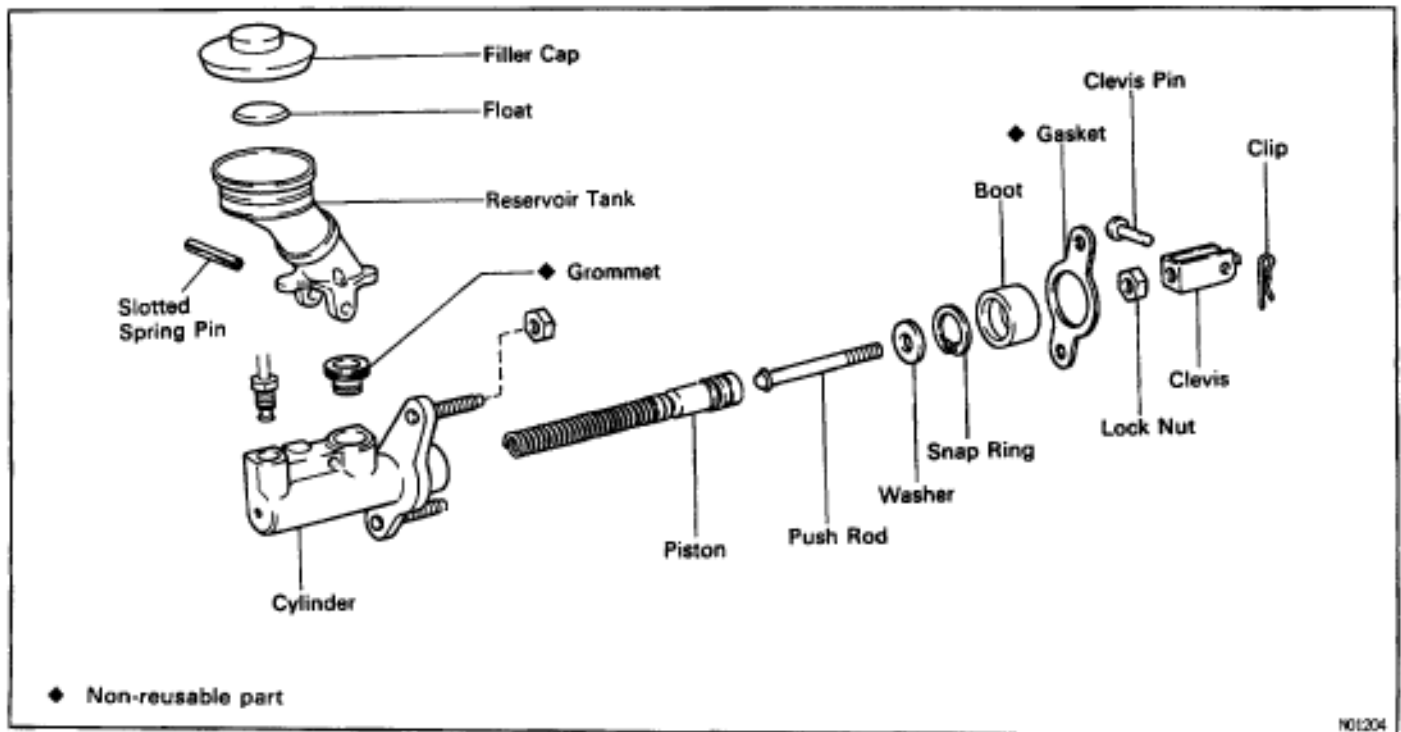

The procedures are presented in a step-by-step format:

- The illustration shows what to do and where to do it.
- The task heading tells what to do.
- The detailed text tells how to perform the task and gives other information such as specifications and warnings.

Example:

Task heading : what to do

21. CHECK PISTON STROKE OF OVERDRIVE BRAKE

(a) Place SST and a dial indicator onto the overdrive brake piston as shown in the illustration.

SST 09350-30020 (09350-06120)

Set part No. *Component part No.*

Detailed text: how to do task

(b) Measure the stroke applying and releasing the compressed air (392 – 785 kPa, 4 – 8 kgf/cm² or 57 – 114 psi) as shown in the illustration.

Piston stroke: 1.40 – 1.70 mm (0.0551 – 0.0669 in.)

Specification

This format provides the experienced technician with a FAST TRACK to the information needed. The upper case task heading can be read at a glance when necessary, and the text below it provides detailed information. Important specifications and warnings always stand out in bold type.

REFERENCES

References have been kept to a minimum. However, when they are required you are given the page to refer to.

SPECIFICATIONS

Specifications are presented in bold type throughout the text where needed. You never have to leave the procedure to look up your specifications. They are also found at the end of each section, for quick reference.

CAUTIONS, NOTICES, HINTS:

- CAUTIONS are presented in bold type, and indicate there is a possibility of injury to you or other people.
- NOTICES are also presented in bold type, and indicate the possibility of damage to the components being repaired.
- HINTS are separated from the text but do not appear in bold. They provide additional information to help you perform the repair efficiently.

SI UNIT

The UNITS given in this manual are primarily expressed according to the SI UNIT (International System of Unit), and alternately expressed in the metric system and in the English System.

Example:

Torque: 30 N·m (310 kgf·cm, 22 ft·lbf)

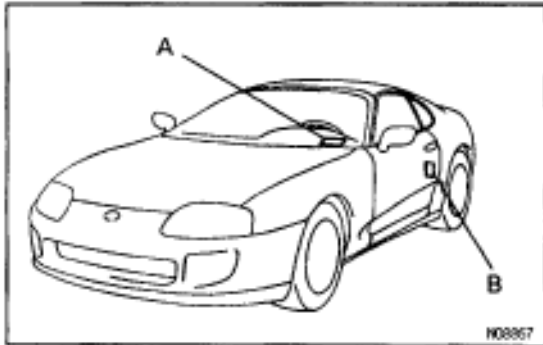

IDENTIFICATION INFORMATION VEHICLE IDENTIFICATION NUMBER

The vehicle identification number is stamped on the vehicle identification number plate and certification label.

- A. Vehicle Identification Number Plate
- B. Certification Label

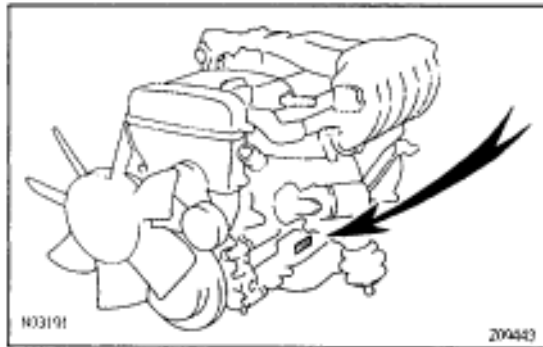

ENGINE SERIAL NUMBER

The engine serial number is stamped on the engine block as shown.

CAUTIONS, NOTICES, HINTS:

- CAUTIONS are presented in bold type, and indicate there is a possibility of injury to you or other people.
- NOTICES are also presented in bold type, and indicate the possibility of damage to the components being repaired.
- HINTS are separated from the text but do not appear in bold. They provide additional information to help you perform the repair efficiently.

SI UNIT

The UNITS given in this manual are primarily expressed according to the SI UNIT (International System of Unit), and alternately expressed in the metric system and in the English System.

Example:

Torque: 30 N·m (310 kgf·cm, 22 ft·lbf)

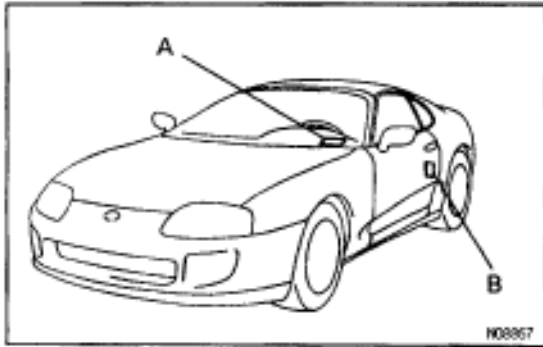

IDENTIFICATION INFORMATION VEHICLE IDENTIFICATION NUMBER

The vehicle identification number is stamped on the vehicle identification number plate and certification label.

- A. Vehicle Identification Number Plate
- B. Certification Label

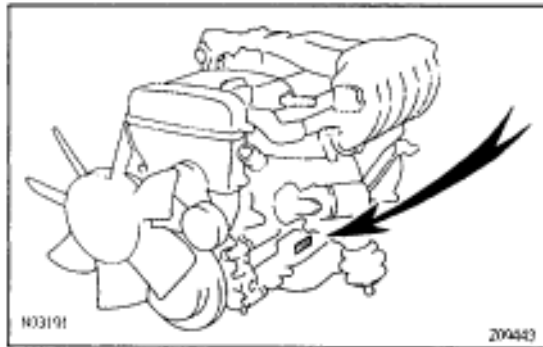

ENGINE SERIAL NUMBER

The engine serial number is stamped on the engine block as shown.

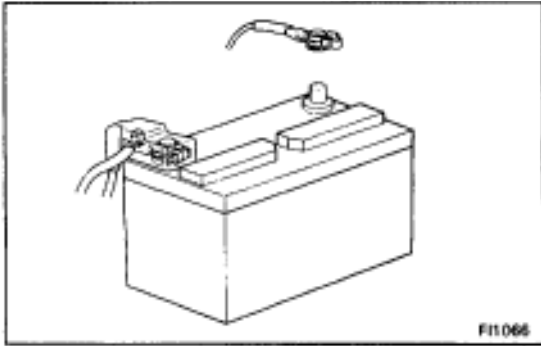

GENERAL REPAIR INSTRUCTIONS

1. Use fender, seat and floor covers to keep the vehicle clean and prevent damage.
2. During disassembly, keep parts in the appropriate order to facilitate reassembly.
3. Observe the following:
 - (a) Before performing electrical work, disconnect the negative (-) terminal cable from the battery.
 - (b) If it is necessary to disconnect the battery for inspection or repair, always disconnect the negative (-) terminal cable which is grounded to the vehicle body.
 - (c) To prevent damage to the battery terminal, loosen the cable nut and raise the cable straight up without twisting or prying it.
 - (d) Clean the battery terminals and cable ends with a clean shop rag. Do not scrape them with a file or other abrasive objects.
 - (e) Install the cable ends to the battery terminals with the nut loose, and tighten the nut after installation. Do not use a hammer to tap the cable ends onto the terminals.
 - (f) Be sure the cover for the positive (+) terminal is properly in place.
4. Check hose and wiring connectors to make sure that they are secure and correct.
5. Non-reusable parts
 - (a) Always replace cotter pins, gaskets, O-rings and oil seals etc. with new ones.
 - (b) Non-reusable parts are indicated in the component illustrations by the "◆" symbol.

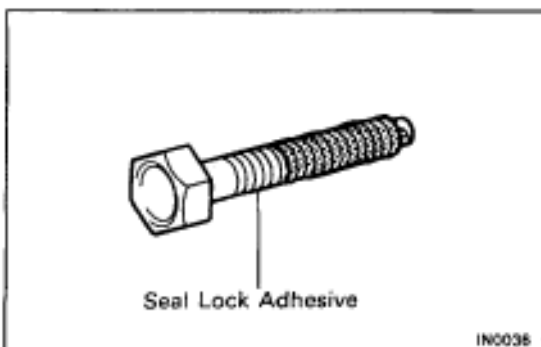

6. Precoated parts

Precoated parts are bolts and nuts, etc. that are coated with a seal lock adhesive at the factory.

 - (a) If a precoated part is retightened, loosened or caused to move in any way, it must be recoated with the specified adhesive.

- (b) When reusing precoated parts, clean off the old adhesive and dry with compressed air. Then apply the specified seal lock adhesive to the bolt, nut or threads.
- (c) Precoated parts are indicated in the component illustrations by the "•" symbol.
- 7. When necessary, use a sealer on gaskets to prevent leaks.
- 8. Carefully observe all specifications for bolt tightening torques. Always use a torque wrench.
- 9. Use of special service tools (SST) and special service materials (SSM) may be required, depending on the nature of the repair. Be sure to use SST and SSM where specified and follow the proper work procedure. A list of SST and SSM can be found in the preparation part at the front of each section in this manual.

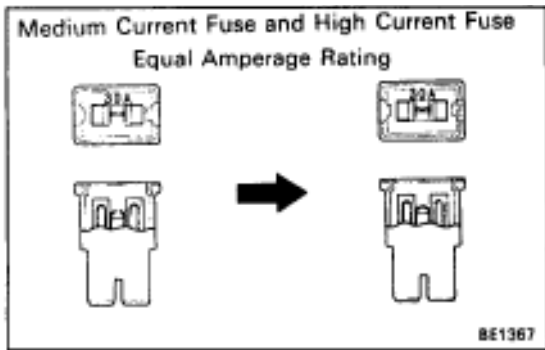

- 10. When replacing fuses, be sure the new fuse has the correct amperage rating. DO NOT exceed the rating or use one with a lower rating.

Illustration	Symbol	Part Name	Abbreviation
<p>BE5594</p>	<p>IN0365</p>	FUSE	FUSE
<p>BE5595</p>	<p>IN0365</p>	MEDIUM CURRENT FUSE	M-FUSE
<p>BE5596</p>	<p>IN0367</p>	HIGH CURRENT FUSE	H-FUSE
<p>BE5597</p>	<p>IN0367</p>	FUSIBLE LINK	FL
<p>BE5598</p>	<p>IN0368</p>	CIRCUIT BREAKER	CB

11. Care must be taken when jacking up and supporting the vehicle. Be sure to lift and support the vehicle at the proper locations (See page IN-36).
 - (a) If the vehicle is to be jacked up only at the front or rear end, be sure to block the wheels at the opposite end in order to ensure safety.
 - (b) After the vehicle is jacked up, be sure to support it on stands. It is extremely dangerous to do any work on a vehicle raised on a jack alone, even for a small job that can be finished quickly.
12. Observe the following precautions to avoid damage to the following parts:
 - (a) Do not open the cover or case of the ECU, ECM, PCM or TCM unless absolutely necessary. (If the IC terminals are touched, the IC may be destroyed by static electricity.)

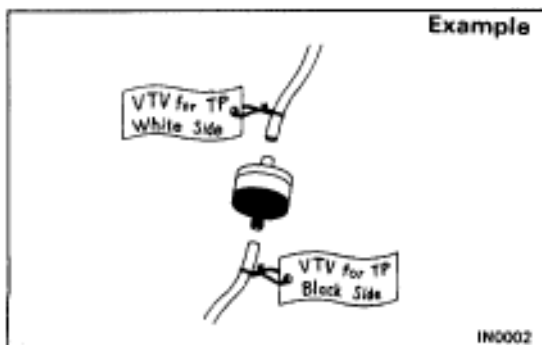
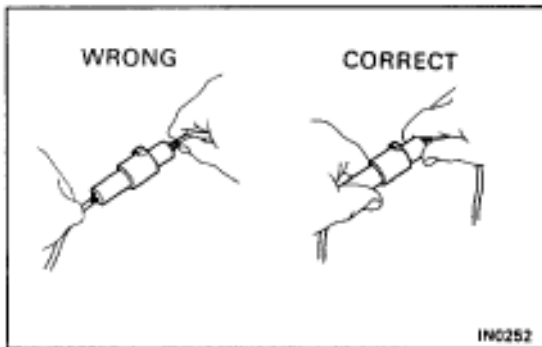
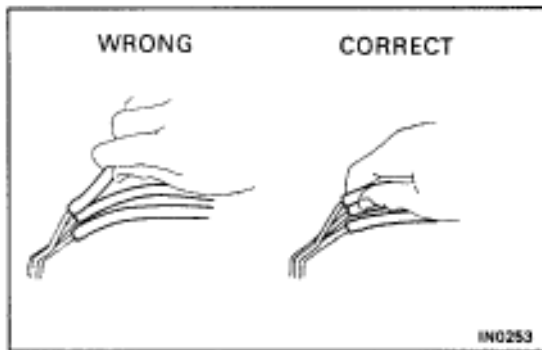

- (b) To disconnect vacuum hoses, pull on the end, not the middle of the hose.
- (c) To pull apart electrical connectors, pull on the connector itself, not the wires.
- (d) Be careful not to drop electrical components, such as sensors or relays. If they are dropped on a hard floor, they should be replaced and not reused.
- (e) When steam cleaning an engine, protect the distributor, air filter, and VCV from water.
- (f) Never use an impact wrench to remove or install temperature switches or temperature sensors.
- (g) When checking continuity at the wire connector, insert the tester probe carefully to prevent terminals from bending.
- (h) When using a vacuum gauge, never force the hose onto a connector that is too large. Use a step-down adapter instead. Once the hose has been stretched, it may leak.

13. Tag hoses before disconnecting them:
 - (a) When disconnecting vacuum hoses, use tags to identify how they should be reconnected.
 - (b) After completing a job, double check that the vacuum hoses are properly connected. A label under the hood shows the proper layout.

14. Unless otherwise stated, all resistance is measured at an ambient temperature of 20°C (68°F). Because the resistance may be outside specifications if measured at high temperatures immediately after the vehicle has been running, measurements should be made when the engine has cooled down.

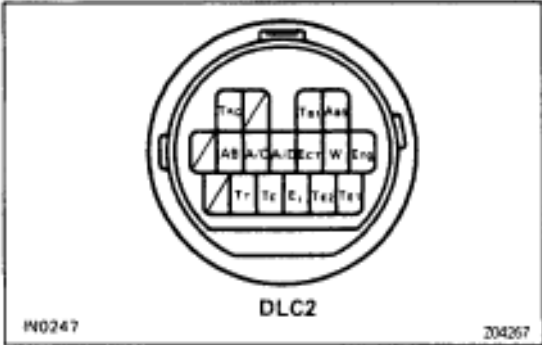
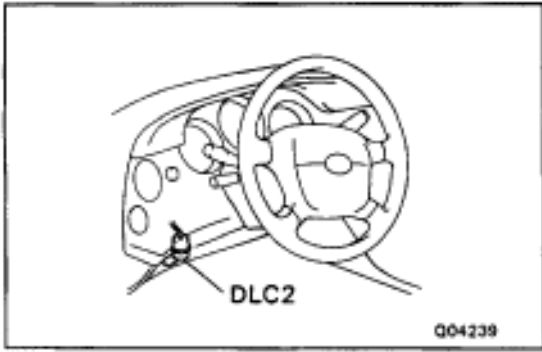

FOR VEHICLES WITH DATA LINK CONNECTOR 2 (DLC2)

The DLC2 is provided inside the cabin (located under the left side instrument panel) as a connector exclusively for diagnosis of data from the Engine, Automatic Transmission, ABS, A/C, Airbag, Traction Control and Cruise Control System to improve serviceability. The DLC1 inside the engine compartment is used for engine adjustment.

Connecting the following terminals of the DLC2 to terminal E₁ selects the diagnosis mode shown.

NOTICE: Never make a mistake with the terminal connection position as this will cause a malfunction.

Terminal	Diagnosis Mode (System)
T _{E1}	Engine and automatic transmission (Normal mode)
T _{E2} and T _{E1}	Engine and automatic transmission (Test mode)
T _C	ABS, A/C, Airbag, Traction Control and Cruise Control System
T _T	Automatic transmission

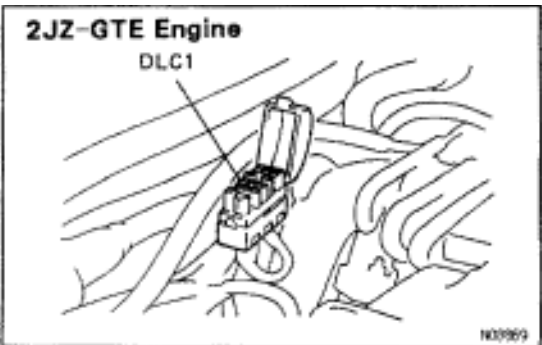
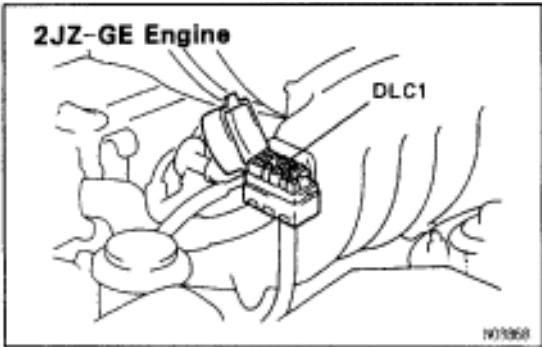

Refer to the respective system for the inspection method.
 HINT: By connecting the DLC2 up to a monitor specifically designed for use with the DLC2, the diagnosis result for each system can be read easily.

PRECAUTION FOR VEHICLES EQUIPPED WITH SRS AIRBAG

The 1995 SUPRA is equipped with an SRS (Supplemental Restraint System), such as the driver airbag, front passenger airbag and seat belt pretensioners.

Failure to carry out service operations in the correct sequence could cause the supplemental restraint system to unexpectedly deploy during servicing, possibly leading to a serious accident.

Further, if a mistake is made in servicing the supplemental restraint system, it is possible the SRS may fail to operate when required. Before servicing (including removal or installation of parts, inspection or replacement), be sure to read the following items carefully, then follow the correct procedure described in this manual.

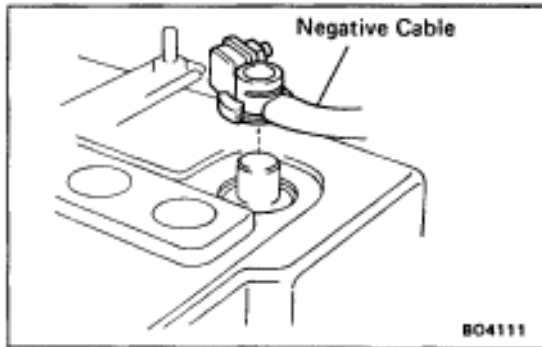

1. Malfunction symptoms of the supplemental restraint system are difficult to confirm, so the diagnostic trouble codes become the most important source of information when troubleshooting. When troubleshooting the supplemental restraint system, always inspect the diagnostic trouble codes before disconnecting the battery (See page [RS-41](#)).
2. **Work must be started after 90 seconds from the time the ignition switch is turned to the LOCK position and the negative (-) terminal cable is disconnected from the battery.**

(The supplemental restraint system is equipped with a back-up power source so that if work is started within 90 seconds of disconnecting the negative (-) terminal cable from the battery, the SRS may deploy.)

When the negative (–) terminal cable is disconnected from the battery, memory of the clock and audio systems will be cancelled. So before starting work, make a record of the contents memorized by the audio memory system. When work is finished, reset the audio systems as before and adjust the clock.

This vehicle has power tilt and power telescopic steering, power seat, power outside rear view mirror and power shoulder belt anchorage, which are all equipped with memory function, it is not possible to make a record of the memory contents. So when the work is finished, therefore it will be necessary to explain this fact to the customer, and ask the customer to adjust the features and reset the memory.

To avoid erasing the memory of each memory system, never use a back-up power supply from outside the vehicle.

3. Even in cases of a minor collision where the SRS does not deploy, the steering wheel pad, front passenger airbag assembly and front airbag sensors should be inspected (See pages [RS-10](#), 20, 30).
4. Never use SRS parts from another vehicle. When replacing parts, replace them with new parts.
5. Before repairs, remove the airbag sensors if shocks are likely to be applied to the sensors during repairs.
6. Never disassemble and repair the front airbag sensors, center airbag sensor assembly, steering wheel pad or front passenger airbag assembly in order to reuse it.
7. If the front airbag sensors, center airbag sensor assembly, steering wheel pad, front passenger airbag assembly or seat belt pretensioners have been dropped, or if there are cracks, dents or other defects in the case, bracket or connector, replace them with new ones.
8. Do not expose the front airbag sensors, center airbag sensor assembly, steering wheel pad, front passenger airbag assembly or seat belt pretensioners directly to hot air or flames.
9. Use a volt/ohmmeter with high impedance (10 k Ω /V minimum) for troubleshooting of the electrical circuit.
10. Information labels are attached to the periphery of the SRS components. Follow the instructions on the notices.
11. After work on the supplemental restraint system is completed, perform the SRS warning light check (See page [RS-44](#)).

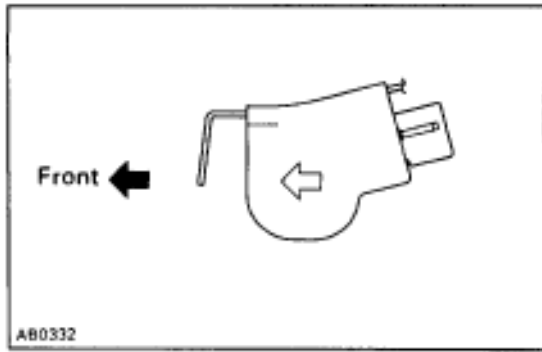

Front Airbag Sensor

1. Never reuse the front airbag sensors involved in a collision that activated the supplemental restraint system. (Replace both left and right airbag sensors.)
2. Install the front airbag sensor with the arrow on the sensor facing toward the front of the vehicle.
3. The front airbag sensor set bolts have been anti-rust treated. When the sensor is removed, always replace the set bolts with new ones.
4. The front airbag sensor is equipped with an electrical connection check mechanism. Be sure to lock this mechanism securely when connecting the connector. If the connector is not securely locked, a malfunction code will be detected by the diagnosis system (See page [RS-7](#)).

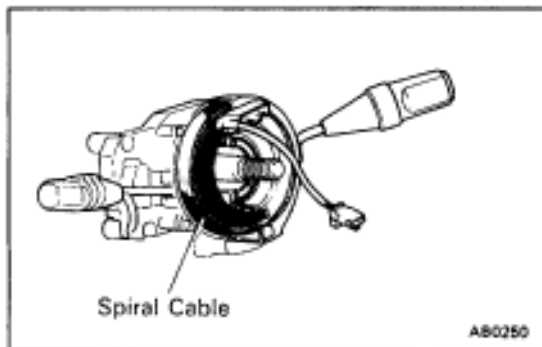

Spiral Cable (in Combination Switch)

The steering wheel must be fitted correctly to the steering column with the spiral cable at the neutral position, otherwise cable disconnection and other troubles may result. Refer to page [SR-14](#) of this manual concerning correct steering wheel installation.

Steering Wheel Pad (with Airbag)

1. **When removing the steering wheel pad or handling a new steering wheel pad, it should be placed with the pad top surface facing up.**
In this case, the twin-lock type connector lock lever should be in the locked state and care should be taken to place it so the connector will not be damaged. In addition do not store a steering wheel pad on top of another one. Storing the pad with its metallic surface up may lead to a serious accident if the airbag inflates for some reason.
2. **Never measure the resistance of the airbag squib. (This may cause the airbag to deploy, which is very dangerous.)**
3. Grease should not be applied to the steering wheel pad and the pad should not be cleaned with detergents of any kind.
4. Store the steering wheel pad where the ambient temperature remains below 93°C (200°F), without high humidity and away from electrical noise.

5. When using electric welding, first disconnect the airbag connector (yellow color and 2 pins) under the steering column near the combination switch connector before starting work.
6. **When disposing of a vehicle or the steering wheel pad alone, the airbag should be deployed using an SST before disposal (See page RS-13). Perform the operation in a safe place away from electrical noise.**

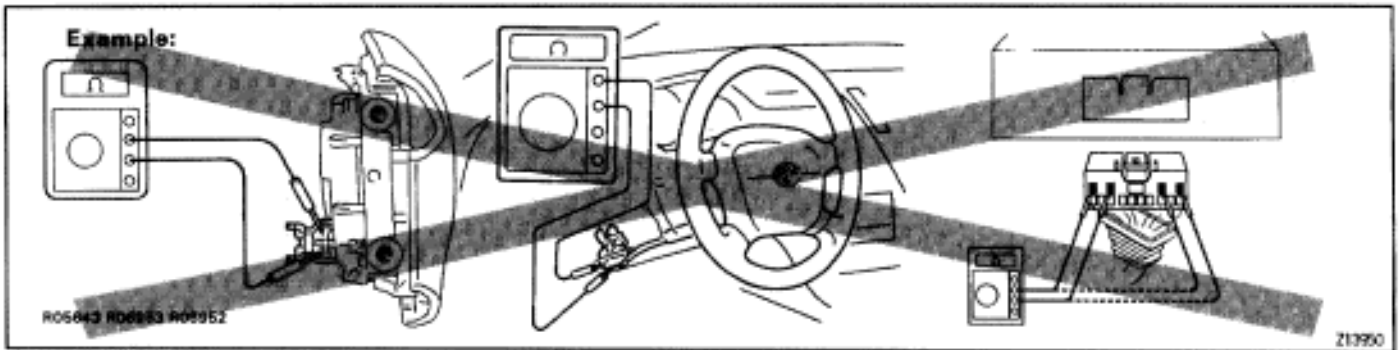
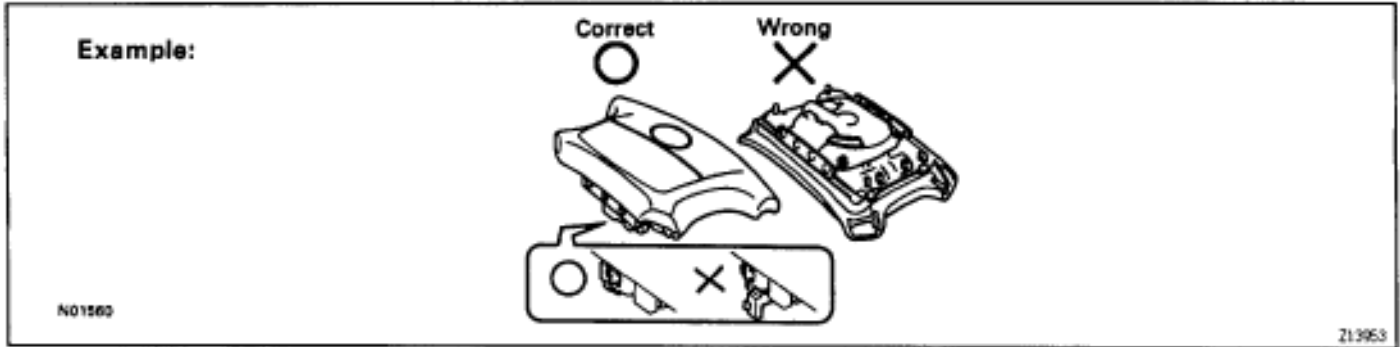

Front Passenger Airbag Assembly

1. **Always store a removed or new front passenger airbag assembly with the airbag door facing up. Storing the airbag assembly with the airbag door facing down could cause a serious accident if the airbag inflates.**
2. **Never measure the resistance of the airbag squib. (This may cause the airbag deploy, which is very dangerous.)**
3. Grease should not be applied to the front passenger airbag assembly and the airbag door should not be cleaned with detergents of any kind.
4. Store the airbag assembly where the ambient temperature remains below 93°C (200°F), without high humidity and away from electrical noise.

5. When using electric welding, first disconnect the airbag connector (yellow color and 2 pins) installed on the glove compartment finish plate at the left side of the glove compartment before starting work.
6. **When disposing of a vehicle or the airbag assembly alone, the airbag should be deployed using an SST before disposal (See page RS-25). Perform the operation in a safe place away from electrical noise.**

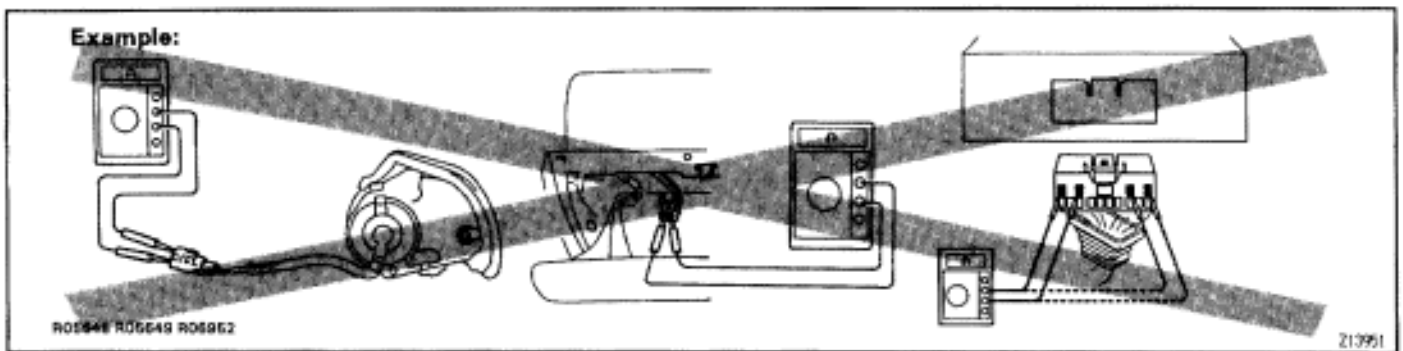
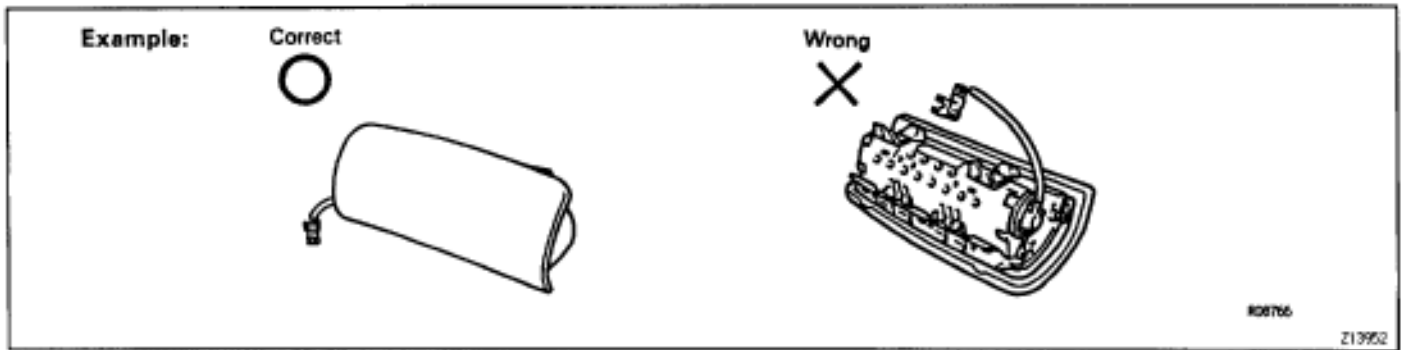

Center Airbag Sensor Assembly

1. Never reuse the center airbag sensor assembly involved in a collision when the SRS has deployed.
2. The connectors to the center airbag sensor assembly should be connected or disconnected with the sensor mounted on the floor. If the connectors are connected or disconnected while the center airbag sensor assembly is not mounted to the floor, it could cause undesired ignition of the supplemental restraint system.
3. Work must be started after 90 seconds from the time the ignition switch is turned to the LOCK position and the negative (-) terminal cable is disconnected from the battery, even if only loosening the set bolts of the center airbag sensor assembly.

Wire Harness and Connector

The SRS wire harness is integrated with the cowl wire harness assembly and floor wire harness assembly. The wires for the SRS wire harness are encased in a yellow corrugated tube. All the connectors for the system are also a standard yellow color. If the SRS wire harness becomes disconnected or the connector becomes broken due to an accident, etc., repair or replace it as shown on page [RS-36](#).

FOR VEHICLES EQUIPPED WITH A CATALYTIC CONVERTER

CAUTION: If large amounts of unburned gasoline flow into the converter, it may overheat and create a fire hazard. To prevent this, observe the following precautions and explain them to your customer.

1. **Use only unleaded gasoline.**
2. **Avoid prolonged idling.**
Avoid running the engine at idle speed for more than 20 minutes.
3. **Avoid spark jump test.**
 - (a) Perform spark jump test only when absolutely necessary. Perform this test as rapidly as possible.
 - (b) While testing, never race the engine.
4. **Avoid prolonged engine compression measurement.**
Engine compression tests must be done as rapidly as possible.
5. **Do not run engine when fuel tank is nearly empty.**
This may cause the engine to misfire and create an extra load on the converter.
6. **Avoid coasting with ignition turned off and prolonged braking.**
7. **Do not dispose of used catalyst along with parts contaminated with gasoline or oil.**

FOR VEHICLES EQUIPPED WITH TRACTION CONTROL (TRAC) SYSTEM

When using a rear wheel two-wheel drum tester such as a speedometer tester or chassis dynamometer, etc., or jacking up the rear wheels and driving the wheels, always push in the TRAC cut ("TRAC OFF") switch and turn the TRAC system OFF.

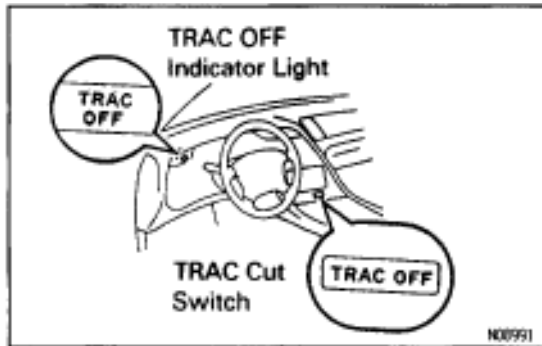

CONFIRM TRAC SYSTEM IS OFF

1. Press the TRAC cut ("TRAC OFF") switch.
2. Check that the TRAC OFF indicator light comes on when the TRAC system is turned off by the TRAC cut switch.

HINT: The TRAC indicator light should always operate right after the engine is restarted.

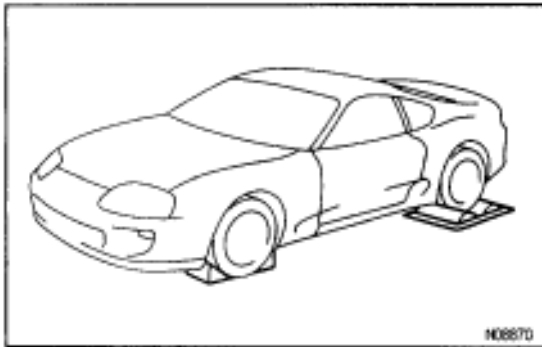

3. Begin measurements.

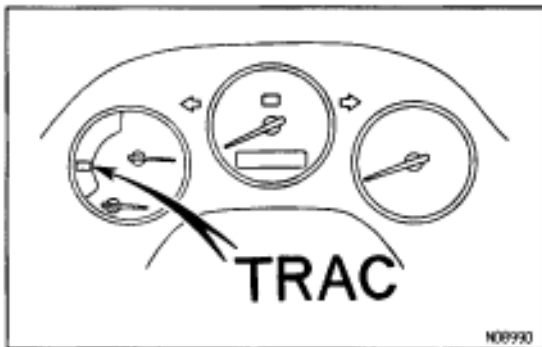

4. Press the TRAC cut switch again to change the TRAC to operative and check that the TRAC OFF indicator light goes off.

HINT: The TRAC indicator light blinks when the TRAC system is operative.

INSPECTION AND ADJUSTMENT OF JOINT ANGLE DURING REMOVAL AND INSTALLATION OF PROPELLER SHAFT

When performing operations which involve the removal and installation of the propeller shaft, always check the joint angle. Make adjustments if necessary (See page [PR-18](#)).

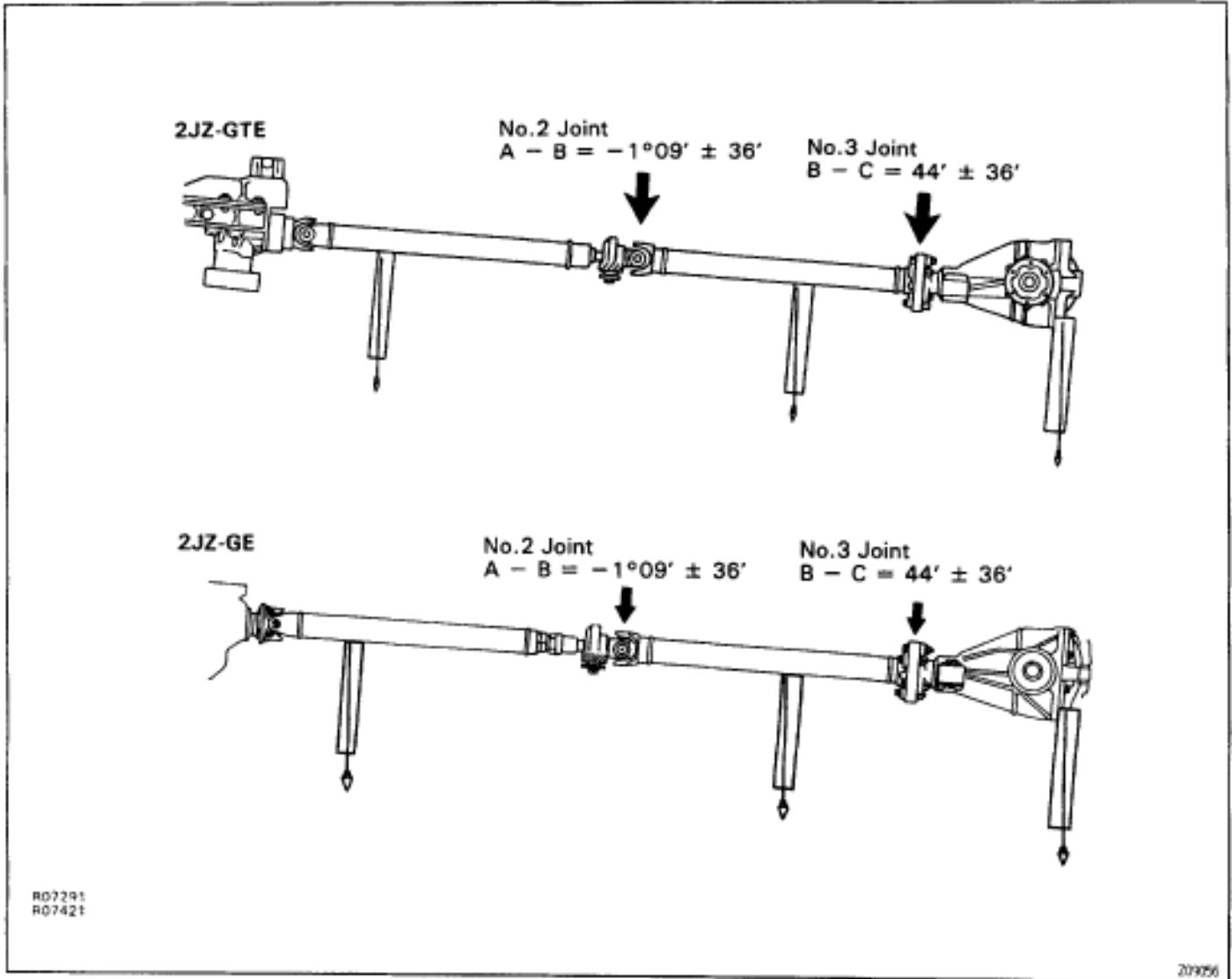

IF VEHICLE IS EQUIPPED WITH MOBILE COMMUNICATION SYSTEM

For vehicles with mobile communication systems such as two-way radios and cellular telephones, observe the following precautions.

- (1) Install the antenna as far as possible away from the ECM, ECU and sensors of the vehicle's electronic system.
- (2) Install the antenna feeder at least 20 cm (7.87 in.) away from the ECM, ECU and sensors of the vehicle's electronics systems. For details about ECM, ECU and sensors locations, refer to the section on the applicable component.
- (3) Do not wind the antenna feeder together with the other wiring. As much as possible, also avoid running the antenna feeder parallel with other wire harnesses.
- (4) Confirm that the antenna and feeder are correctly adjusted.
- (5) Do not install powerful mobile communications system.

HOW TO TROUBLESHOOT ECU CONTROLLED SYSTEMS

A large number of ECU controlled systems are used in the TOYOTA SUPRA. In general, the ECU controlled system is considered to be a very intricate system requiring a high level of technical knowledge and expert skill to troubleshoot. However, the fact is that if you proceed to inspect the circuits one by one, troubleshooting of these systems is not complex. If you have adequate understanding of the system and a basic knowledge of electricity, accurate diagnosis and necessary repair can be performed to locate and fix the problem. This manual is designed through emphasis of the above standpoint to help service technicians perform accurate and effective troubleshooting, and is compiled for the following major ECU controlled systems:

Repair Manual	System		Page
Vol. 1	1.	2JZ-GE Engine	EG-381
		2JZ-GTE Engine	EG-487
Vol. 2	2.	A340E (2JZ-GE) Automatic Transmission	AT1-31
		A340E (2JZ-GTE) Automatic Transmission	AT1-31
	3.	Anti-Lock Brake	BR-51
	4.	Traction Control	BR-123
	5.	Supplemental Restraint System	RS-41
	6.	Theft Deterrent and Door Lock System	BE-142
	7.	Cruise Control	BE-163
	8.	Air Conditioning	AC-13

The troubleshooting procedure and how to make use of it are described on the following pages.

HOW TO PROCEED WITH TROUBLESHOOTING

Carry out troubleshooting in accordance with the procedure on the following page. Here, only the basic procedure is shown. Details are provided in each section, showing the most effective methods for each circuit. Confirm the troubleshooting procedures first for the relevant circuit before beginning troubleshooting of that circuit.

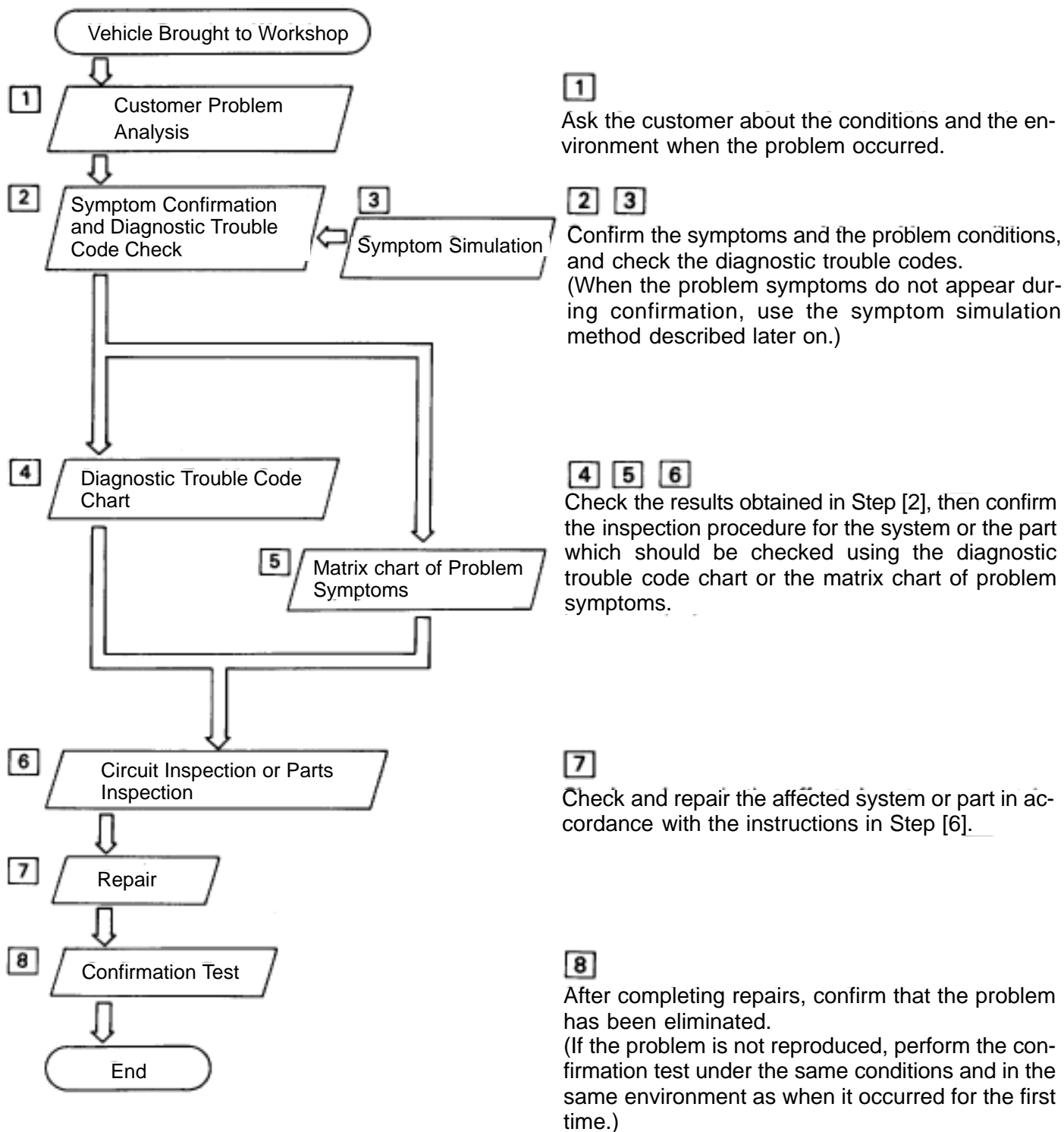

[1] CUSTOMER PROBLEM ANALYSIS

In troubleshooting, the problem symptoms must be confirmed accurately and all preconceptions must be cleared away in order to give an accurate judgment. To ascertain just what the problem symptoms are, it is extremely important to ask the customer about the problem and the conditions at the time it occurred.

Important Points in the Problem Analysis

The following 5 items are important points in the problem analysis. Past problems which are thought to be unrelated and the repair history, etc. may also help in some cases, so as much information as possible should be gathered and its relationship with the problem symptoms should be correctly ascertained for reference in troubleshooting. A customer problem analysis table is provided in the troubleshooting section for each system for your use.

Important Points in the Customer Problem Analysis

- What Vehicle model, system name
- When Date, time, occurrence frequency
- Where Road conditions
- Under what conditions?..... Running conditions, driving conditions, weather conditions
- How did it happen? Problem symptoms

(Sample) Engine control system check sheet.

CUSTOMER PROBLEM ANALYSIS CHECK SHEET			
ENGINE CONTROL System Check Sheet			Inspector's Name _____
Customer's Name		Registration No.	
		Registration Year	/ /
		Frame No.	
Date Vehicle Brought In		Odometer Reading	km Miles
Date Problem Occurred			
Frequency Problem Occurs	<input type="checkbox"/> Constant <input type="checkbox"/> Sometimes (times per day/month) <input type="checkbox"/> Once only <input type="checkbox"/> Other ()		
Conditions When Problem Occurs	Weather	<input type="checkbox"/> Fine <input type="checkbox"/> Cloudy <input type="checkbox"/> Rainy <input type="checkbox"/> Snowy <input type="checkbox"/> Various/Other ()	
	Outdoor Temperature	<input type="checkbox"/> Hot <input type="checkbox"/> Warm <input type="checkbox"/> Cool <input type="checkbox"/> Cold (Approx. °F(°C))	
	Place	<input type="checkbox"/> Highway <input type="checkbox"/> Suburbs <input type="checkbox"/> Inner City <input type="checkbox"/> Hill (<input type="checkbox"/> Up, <input type="checkbox"/> Down) <input type="checkbox"/> Rough road <input type="checkbox"/> Other ()	
	Engine Temp.	<input type="checkbox"/> Cold <input type="checkbox"/> Warming up <input type="checkbox"/> After warming up <input type="checkbox"/> Any temp. <input type="checkbox"/> Other ()	
	Engine Operation	<input type="checkbox"/> Starting <input type="checkbox"/> Just after starting <input type="checkbox"/> Idling <input type="checkbox"/> Racing without load <input type="checkbox"/> Driving (<input type="checkbox"/> Constant speed <input type="checkbox"/> Acceleration <input type="checkbox"/> Deceleration <input type="checkbox"/> Other ()	
<input type="checkbox"/> Engine does not crank <input type="checkbox"/> No initial combustion <input type="checkbox"/>			
<input type="checkbox"/> Engine cranks slowly other ()			
<input type="checkbox"/> first idle <input type="checkbox"/> Idling rpm is at <input type="checkbox"/> Other ()			

[2] SYMPTOM CONFIRMATION AND DIAGNOSTIC TROUBLE CODE CHECK

The diagnostic system in the TOYOTA SUPRA fulfills various functions. The first function is the Diagnostic Trouble Code Check in which a malfunction in the signal circuits to the ECU is stored in code in the ECU memory at the time of occurrence, to be output by the technician during troubleshooting. Another function is the Input Signal Check which checks if the signals from various switches are sent to the ECU correctly. The air conditioning system has an Actuator Check function whereby the ECU automatically operates the actuators of the damper and blowermotor, etc. to check the operation. By using these check functions, the problem areas can be narrowed down quickly and troubleshooting can be performed effectively. Diagnostic functions are incorporated in the following systems in the TOYOTA SUPRA.

System	Diagnostic Trouble Code Check	Input Signal Check (Sensor Check)	Other Diagnosis Function
Engine	○ (with Test Mode)	○	
Automatic Transmission	○ (with Test Mode)	○	
Anti-Lock Brake	○	○	
Traction Control (Option)	○	○	
Supplemental Restraint System	○		
Cruise Control	○	○	
Air Conditioning	○	○	Actuator Check

In diagnostic trouble code check, it is very important to determine whether the problem indicated by the diagnostic trouble code is still occurring or occurred in the past but returned to normal at present. In addition, it must be checked in the problem symptom check whether the malfunction indicated by the diagnostic trouble code is directly related to the problem symptom or not. For this reason, the diagnostic trouble codes should be checked before and after the symptom confirmation to determine the current conditions, as shown in the table below. If this is not done, it may, depending on the case, result in unnecessary troubleshooting for normally operating systems, thus making it more difficult to locate the problem, or in repairs not pertinent to the problem. Therefore, always follow the procedure in correct order and perform the diagnostic trouble code check.

DIAGNOSTIC TROUBLE CODE CHECK PROCEDURE

Diagnostic Trouble Code Check (Make a note of and then clear)	Confirmation of symptoms	Diagnostic Trouble Code Check	Problem Condition
Diagnostic Trouble Code Display ⇒	Problem symptoms exist	Same Diagnostic trouble code is displayed	Problem is still occurring in the diagnostic circuit
		Normal code is displayed	The problem is still occurring in a place other than in the diagnostic circuit. (The diagnostic trouble code displayed first is either for a past problem or it is a secondary problem.)
	No problem symptoms exist		The problem occurred in the diagnostic circuit in the past.
Normal Code Display ⇒	Problem symptoms exist	Normal code is displayed	The problem is still occurring in a place other than in the diagnostic circuit.
	No problem symptoms exist	Normal code is displayed	The problem occurred in a place other than in the diagnostic circuit in the past.

Taking into account the above points, a flow chart showing how to proceed with troubleshooting using the diagnostic trouble code check is shown below. This flow chart shows how to utilize the diagnostic trouble code check effectively, then by carefully checking the results, indicates how to proceed either to diagnostic trouble code troubleshooting or to troubleshooting of problem symptoms.

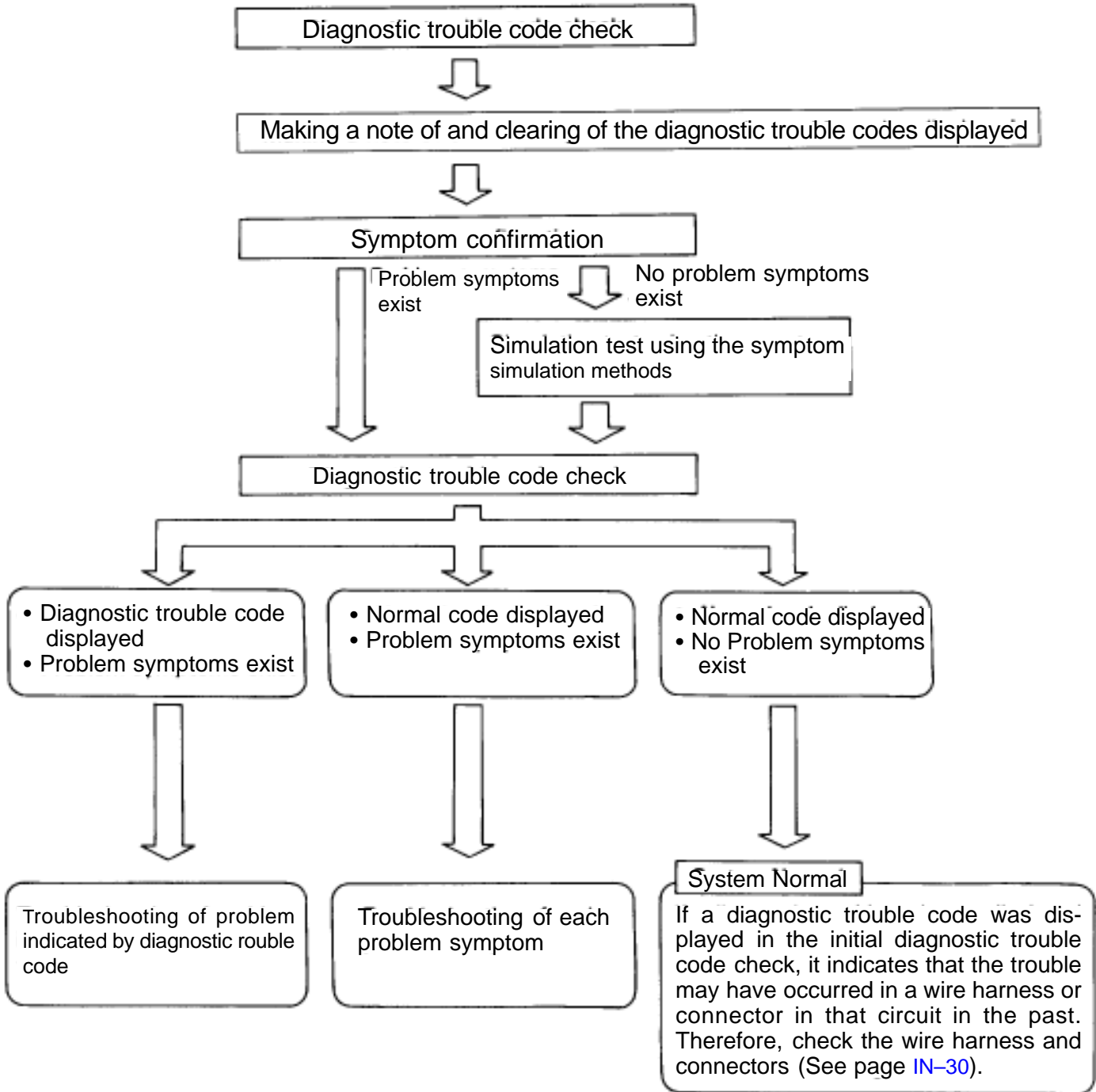

[3] SYMPTOM SIMULATION

The most difficult case in troubleshooting is when there are no problem symptoms occurring. In such cases, a thorough customer problem analysis must be carried out, then simulate the same or similar conditions and environment in which the problem occurred in the customer's vehicle. No matter how much experience a technician has, or how skilled he may be, if he proceeds to troubleshoot without confirming the problem symptoms he will tend to overlook something important in the repair operation and make a wrong guess somewhere, which will only lead to a standstill. For example, for a problem which only occurs when the engine is cold, or for a problem which occurs due to vibration caused by the road during driving, etc., the problem can never be determined so long as the symptoms are confirmed with the engine hot condition or the vehicle at a standstill. Since vibration, heat or water penetration (moisture) are likely causes for problems which are difficult to reproduce, the symptom simulation tests introduced here are effective measures in that the external causes are applied to the vehicle in a stopped condition.

Important Points in the Symptom Simulation Test

In the symptom simulation test, the problem symptoms should of course be confirmed, but the problem area or parts must also be found out. To do this, narrow down the possible problem circuits according to the symptoms before starting this test and connect a tester beforehand. After that, carry out the symptom simulation test, judging whether the circuit being tested is defective or normal and also confirming the problem symptoms at the same time. Refer to the matrix chart of problem symptoms for each system to narrow down the possible causes of the symptom.

<p>1 VIBRATION METHOD: When vibration seems to be the major cause.</p>	
<p>CONNECTORS Slightly shake the connector vertically and horizontally.</p> <p>WIRE HARNESS Slightly shake the connector vertically and horizontally. The connector joint, fulcrum of the vibration, and body through portion are the major areas to be checked thoroughly.</p>	<p>P19981 F12332</p>
<p>PARTS AND SENSORS Apply slight vibration with a finger to the part of the sensor considered to be the problem cause and check if the malfunction occurs. HINT: Applying strong vibration to relays may result in open relays.</p>	<p>P20001</p>

2**HEAT METHOD: When the problem seems to occur when the suspect area is heated**

Heat the component that is the likely cause of the malfunction with a hair dryer or similar object. Check to see if the malfunction occurs.

NOTICE:

- (1) Do not heat to more than 60°C (140°F). (Temperature limit that no damage is done to the component).
- (2) Do not apply heat directly to parts in the ECU.



F12334

3**WATER SPRINKLING METHOD: When the malfunction seems to occur on a rainy day or in a high-humidity condition.**

Sprinkle water onto the vehicle and check to see if the malfunction occurs.

NOTICE:

- (1) Never sprinkle water directly into the engine compartment, but indirectly change the temperature and humidity by applying water spray onto the radiator front surface.
- (2) Never apply water directly onto the electronic components.

(Service hint)

If a vehicle is subject to water leakage, the leaked water may contaminate the ECU. When testing a vehicle with a water leakage problem, special caution must be used.



F16649

4**OTHER: When a malfunction seems to occur when electrical load is excessive.**

Turn on all electrical loads including the heater blower, head lights, rear window defogger, etc. and check to see if the malfunction occurs.

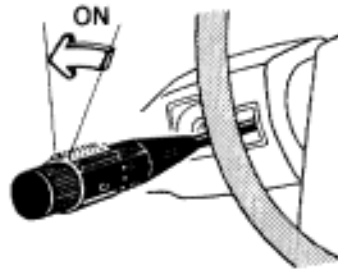

F12336

[4] DIAGNOSTIC TROUBLE CODE CHART



The inspection procedure is shown in the table below. This table permits efficient and accurate troubleshooting using the diagnostic trouble codes displayed in the diagnostic trouble code check. Proceed with troubleshooting in accordance with the inspection procedure given in the diagnostic chart corresponding to the diagnostic trouble codes displayed. The engine diagnostic trouble code chart is shown below as an example.

• **DTC No.**
Indicates the diagnostic trouble code.

• **Circuit to be Checked**
Indicates the circuit or part which needs to be checked.

DIAGNOSTIC TROUBLE CODE CHART

HINT: Parameters listed in the chart may not be exactly the same as your reading due to type of the instruments or other factors.

DTC No.	Number of MIL Blinks	Circuit	Diagnostic Trouble Code Detecting Condition
—		Normal	No code is recorded
12		G, NE Signal (No.1)	No NE or G1 and G2 signal to ECM for 2 sec. or more after cranking Open in "G ⊖" circuit No NE signal to ECM for 0.1 sec. or more NE Signal (No.1) NE signal does not pulse between G1 and G2

• **Diagnostic Trouble Code Detecting Condition**
Indicates the diagnostic trouble code set parameter.

• **Trouble Area**
Indicates the suspect area of the problem.

• **Page or Instructions**
Indicates the page where the inspection procedure for each circuit is to be found, or gives instructions for checking and repairs.

If a malfunction code is displayed during the diagnostic trouble code check in test mode, check the circuit for that code listed in the table below (Proceed to the page given for that circuit).

Trouble Area	Malfunction Indicator Lamp*1		Memory**	See page
	Normal Mode	Test Mode		
—	—	—	—	—
<ul style="list-style-type: none"> Open or short in NE, G circuit Distributor Open or short in STA circuit ECM 	ON	N.A.	○	EG-408
<ul style="list-style-type: none"> Open or short in NE circuit 	ON	N.A.		
	N.A.			

[5] MATRIX CHART OF PROBLEM SYMPTOMS

The suspect circuits or parts for each problem symptom are shown in the table below. Use this table to troubleshoot the problem when a "Normal" code is displayed in the diagnostic trouble code check but the problem is still occurring. Numbers in the table indicate the inspection order in which the circuits or parts should be checked. HINT: When the problem is not detected by the diagnostic system even though the problem symptom is present, it is considered that the problem is occurring outside the detection range of the diagnostic system, or that the problem is occurring in a system other than the diagnostic system.

• **Page**
Indicates the page where the flow chart for each circuit is located.

• **Problem Symptom**

• **Circuit or Part Name**
Indicates the circuit or part which needs to be checked.

MATRIX CHART OF PROBLEM SYMPTOMS

When the malfunction code is not confirmed in the diagnostic trouble code check and the problem still can not be confirmed in the basic inspection, proceed to this matrix chart and troubleshoot according to the numbered order given below.

Symptom		Suspect area															See page						
		Volume air flow meter circuit	Starter signal circuit	EGR system	Switch condition signal circuit	Park/neutral position switch circuit	ECM power source circuit	Back up power source circuit	Injector circuit	IAC valve circuit	Fuel pump control circuit	VSV circuit for fuel pressure control	A/C signal circuit (Compressor circuit)	Starter and Starter relay	Ignition signal circuit (Spark test)	Spark plug		Ignition coil	Distributor	Compression	A/T faulty	Theft deterrent ECU	Engine control module (ECM)
Does not start	Engine does not crank					2								1									
	No initial combustion					1		5		3					2	4							
	No complete combustion							6		1					5	4	2	3					
Fault to	Engine cranks normally	1						8	2	3					6	4	5	7					
	Cold engine	1						4	2	3					7	5	6						
		1						5	2	4	3				8								
			1						2														
			1	5	4	6			2														
			3	4		8	6	1					2										

• **Circuit Inspection, Inspection Order**
Indicates the circuit which needs to be checked for each problem symptom. Check in the order indicated by the numbers.

6 CIRCUIT INSPECTION

How to read and use each page is shown below.

- Diagnostic Trouble Code No. and Detection Item

- Circuit Description

The major role and operation, etc. of the circuit and its component parts are explained.

DTC **24** **Intake Air Temp. Sensor Circuit**

CIRCUIT DESCRIPTION

The intake air temp. sensor is built into the volume air flow meter and senses the intake air temperature.

The structure of the sensor and connection to the ECM is the same as in the engine coolant temp. sensor shown on page EG-424.

If the ECM detects the diagnostic trouble code "24", it operates the fail safe function in which the intake air temperature is assumed to be 20°C (68°F).

- Indicates the diagnostic trouble code, diagnostic trouble code set parameter and suspect area of the problem.

DTC No.	Diagnostic Trouble Code Detecting Condition	Trouble Area
24	Open or short in intake air temp. sensor circuit for 0.5 sec. or more	<ul style="list-style-type: none"> • Open or short in intake air temp. sensor circuit • Intake air temp. sensor • ECM

WIRING DIAGRAM

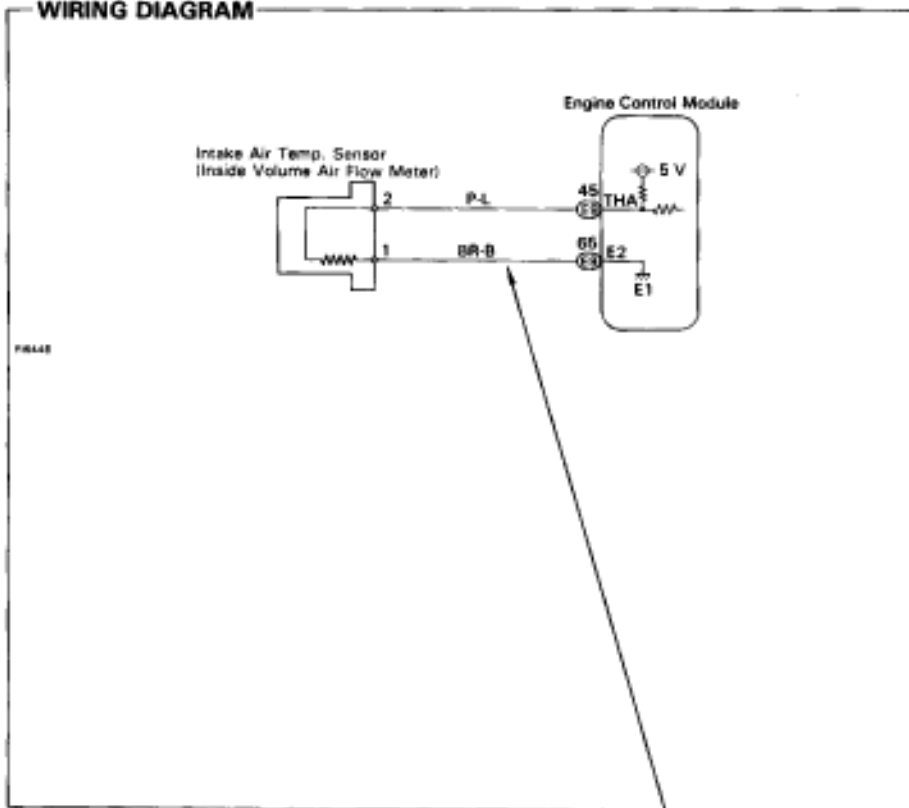

- Wiring Diagram

This shows a wiring diagram of the circuit. Use this diagram together with ELECTRICAL WIRING DIAGRAM to thoroughly understand the circuit.

- Indicates the position of the ignition switch during the check.



- Inspection Procedure

Use the inspection procedure to determine if the circuit is normal or abnormal, and, if it is abnormal, use it to determine whether the problem is located in the sensors, actuators, wire harness or ECU.

2JZ-GE ENGINE TROUBLESHOOTING - CIRCUIT INSPECTION EG-427

INSPECTION PROCEDURE

HINT: If diagnostic trouble codes "22" (engine coolant temperature sensor circuit), "24" (intake air temperature sensor circuit) and "41" (throttle position sensor circuit) are output simultaneously, E2 (sensor ground) may be open.

Check voltage between terminals THA and E2 of engine control module connector.

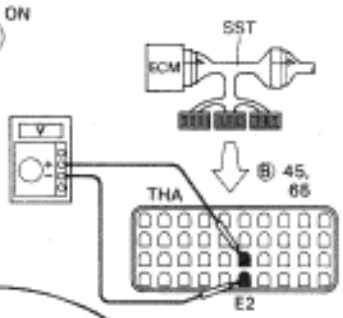

P (1) Connect SST (check harness "A").
(See page EG-404)
SST 09990-01000
(2) Turn ignition switch ON.

C Measure voltage between terminals THA and E2 of engine control module connector.

OK

Intake air temp. °C (°F)	Voltage
20 (68)	0.5 - 3.4 V
80 (140)	0.2

OK Check for intermittent (See page EG-39)

- P** Preparation
- C** Check

- Indicates the place to check the voltage or resistance.
- Indicates the connector position to checked, from the front or back side.



BE4076
Check from the connector back side.
(with harness)



BE4077
Check from the connector front side (without harness)
In this case, care must be taken not to bend the terminals.

- Indicates the condition of the connector of ECU during the check.

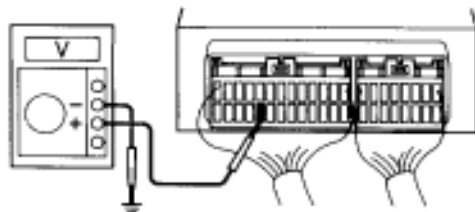

BR5459
Connector being checked is connected.

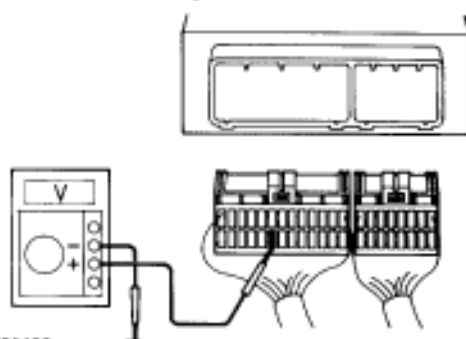

BE5450
Connector being checked is disconnected.

HOW TO USE THE DIAGNOSTIC CHART AND INSPECTION PROCEDURE

1. For troubleshooting, diagnostic trouble code charts or problem symptom charts are provided for each circuit with detailed inspection procedures on the following pages.
2. When all the component parts, wire harnesses and connectors of each circuit except the ECU are found to be normal in troubleshooting, then it is determined that the problem is in the ECU. Accordingly, if diagnosis is performed without the problem symptoms occurring, the instruction will be to check and replace the ECU, even if the problem is not in the ECU. So, always confirm that the problem symptoms are occurring, or proceed with inspection while using the symptom simulation method.
3. The instructions "Check wire harness and connector" and "Check and replace ECU" which appear in the inspection procedure, are common and applicable to all diagnostic trouble codes. Follow the procedure outlined below whenever these instructions appear.

Check Wire Harness and Connector

The problem in the wire harness or connector is an open circuit or a short circuit.

OPEN CIRCUIT:

This could be due to a disconnected wire harness, faulty contact in the connector, a connector terminal pulled out, etc.

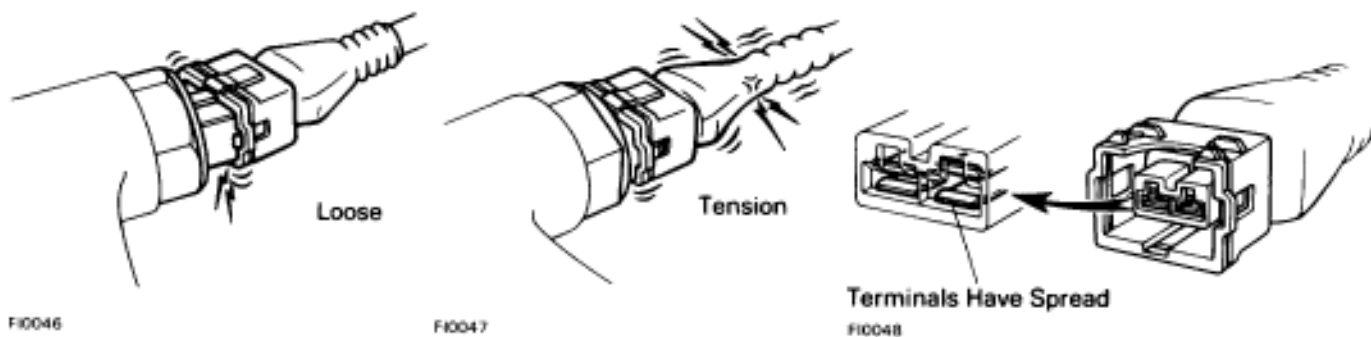

HINT:

1. It is rarely the case that a wire is broken in the middle of it. Most cases occur at the connector. In particular, carefully check the connectors of sensors and actuators.
2. Faulty contact could be due to rusting of the connector terminals, to foreign materials entering terminals or a drop in the contact pressure between the male and female terminals of the connector. Simply disconnecting and reconnecting the connectors once changes the condition of the connection and may result in a return to normal operation.

Therefore, in troubleshooting, if no abnormality is found in the wire harness and connector check, but the problem disappears after the check, then the cause is considered to be in the wire harness or connectors.

SHORT CIRCUIT:

This could be due to a short circuit between the wire harness and the body ground or to a short inside the switch, etc.

HINT:

- When there is a short between the wire harness and body ground, check thoroughly whether the wire harness is caught in the body or is clamped properly.

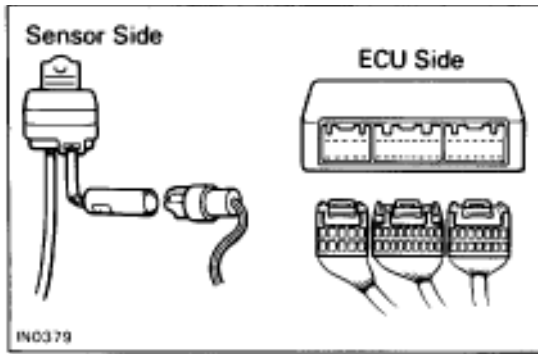

1. CONTINUITY CHECK (OPEN CIRCUIT CHECK)

- (1) Disconnect the connectors at both ECU and sensor sides.
- (2) Measure the resistance between the applicable terminals of the connectors.

Resistance: 1 Ω or less

HINT:

- Measure the resistance while lightly shaking the wire harness vertically and horizontally.
- When tester probes are inserted into a connector, insert the probes from the back. For waterproof connectors in which the probes cannot be inserted from the back, be careful not to bend the terminals when inserting the tester probes.

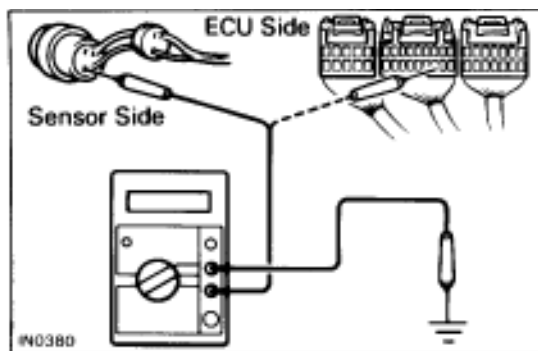
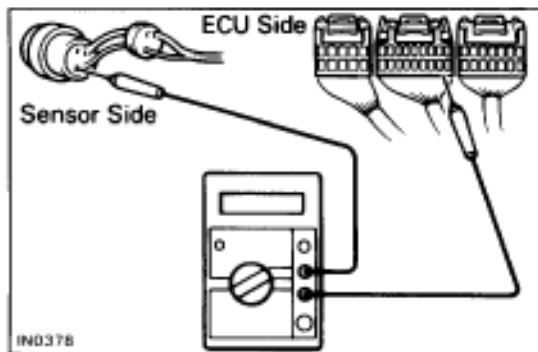

2. RESISTANCE CHECK (SHORT CIRCUIT CHECK)

- (1) Disconnect the connectors at both ends.
- (2) Measure the resistance between the applicable terminals of the connectors and body ground. Be sure to carry out this check on the connectors on both ends.

Resistance: 1 M Ω or higher

HINT: Measure the resistance while lightly shaking the wire harness vertically and horizontally.

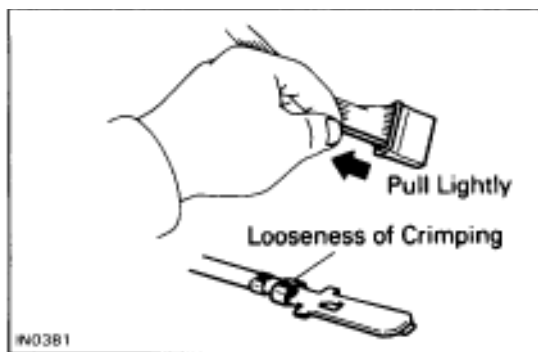

3. VISUAL CHECK AND CONTACT PRESSURE CHECK

- (a) Disconnect the connectors at both ends.
- (b) Check for rust or foreign material, etc. on the terminals of the connectors.
- (c) Check crimped portions for looseness or damage and check if the terminals are secured in the lock position.

HINT: The terminals should not come out when pulled lightly.

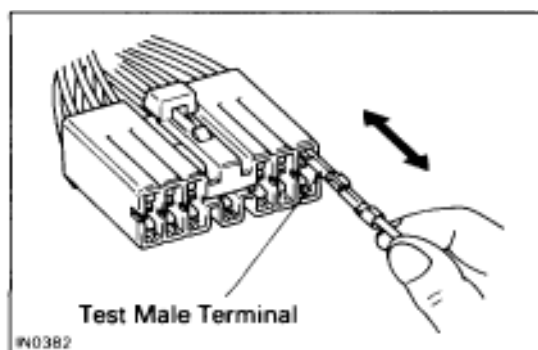

- (d) Prepare a test male terminal and insert it in the female terminal, then pull it out.

HINT: When the test terminal is pulled out more easily than others, there may be poor contact in that section.

Actual examples of the inspection method for open circuit and short circuit are explained below.

1. OPEN CIRCUIT CHECK

For the open circuit in the wire harness in Fig. 1, perform "(a) Continuity Check" or "(b) Voltage Check" to locate the section.

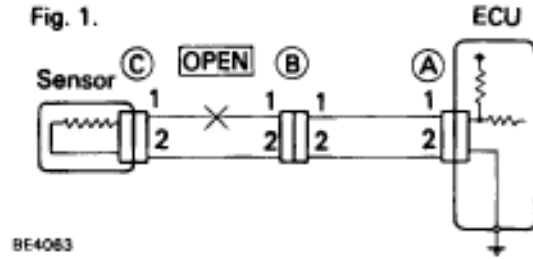

(a) Continuity Check

(1) Disconnect connectors (A) and (C) and measure the resistance between them.

In the case of Fig. 2,

Between terminal 1 of connector (A) and terminal 1 of connector (C) → No continuity (open)

Between terminal 2 of connector (A) and terminal 2 of connector (C) → Continuity

Therefore, it is found out that there is an open circuit between terminal 1 of connector (A) and terminal 1 of connector (C).

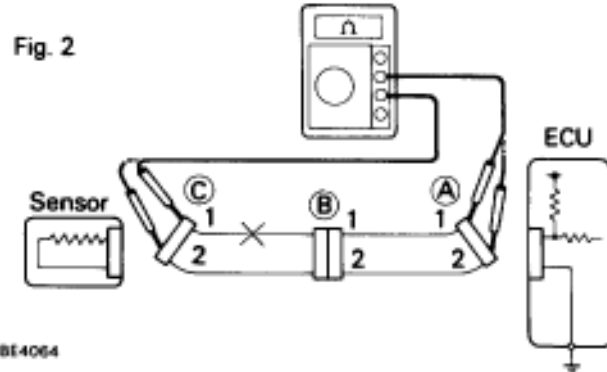

(2) Disconnect connector (B) and measure the resistance between connectors (A) and (B), (B) and (C).

In the case of Fig. 3,

Between terminal 1 of connector (A) and terminal 1 of connector (B) → Continuity

Between terminal 1 of connector (B) and terminal 1 of connector (C) → No Continuity (open)

Therefore, it is found out that there is an open circuit between terminal 1 of connector (B) and terminal 1 of connector (C).

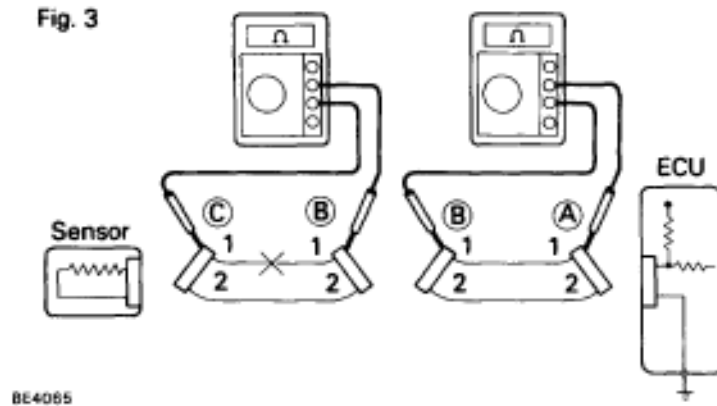

(b) Voltage Check

In a circuit in which voltage is applied (to the ECU connector terminal), an open circuit can be checked for by conducting a voltage check.

- (1) As shown in Fig. 4, with each connector still connected, measure the voltage between body ground and terminal 1 of connector (A) at the ECU 5V output terminal, terminal 1 of connector (B), and terminal 1 of connector (C), in that order.

If the results are:

5 V: Between Terminal 1 of connector (A) and Body Ground

5 V: Between Terminal 1 of connector (B) and Body Ground

0 V: Between Terminal 1 of connector (C) and Body Ground

then it is found out that there is an open circuit in the wire harness between terminal 1 of (B) and terminal 1 of (C).

Fig. 4

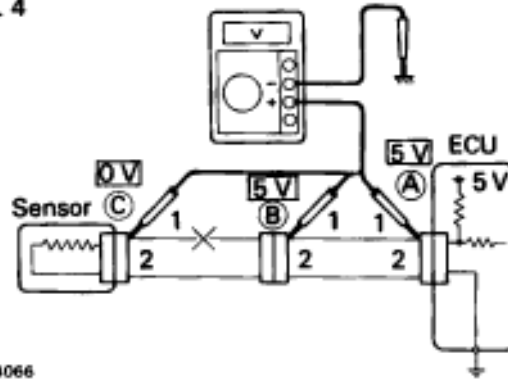

BE4066

2. SHORT CIRCUIT CHECK

If the wire harness is ground shorted as in Fig. 5, locate the section by conducting a "continuity check with ground".

Fig. 5

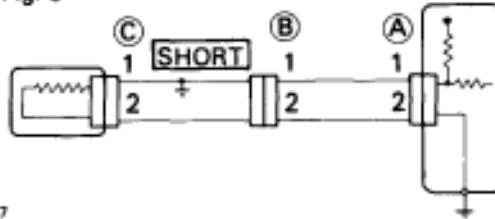

BE4067

(a) Continuity Check with Ground

- (1) Disconnect connectors (A) and (C) and measure the resistance between terminals 1 and 2 of connector (A) and body ground.

In the case of Fig. 6,

Between terminal 1 of connector (A) and body ground → Continuity

Between terminal 2 of connector (A) and body ground → No continuity (open)

Therefore, it is found out that there is a short circuit between terminal 1 of connector (A) and terminal 1 of connector (C).

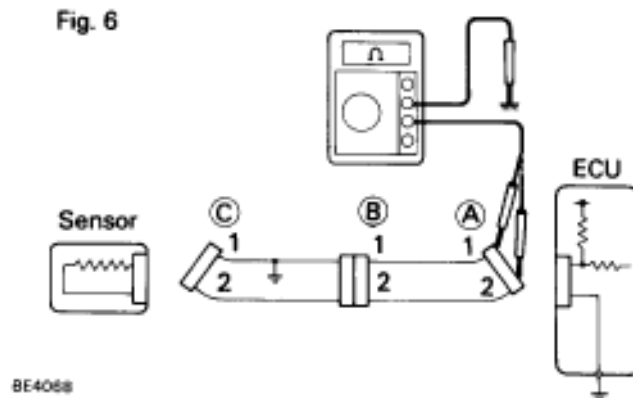

- (2) Disconnect connector (B) and measure the resistance between terminal 1 of connector (A) and body ground, and terminal 1 of connector (B) and body ground.

Between terminal 1 of connector (A) and body ground → No continuity (open)

Between terminal 1 of connector (B) and body ground → Continuity

Therefore, it is found out that there is a short circuit between terminal 1 of connector (B) and terminal 1 of connector (C).

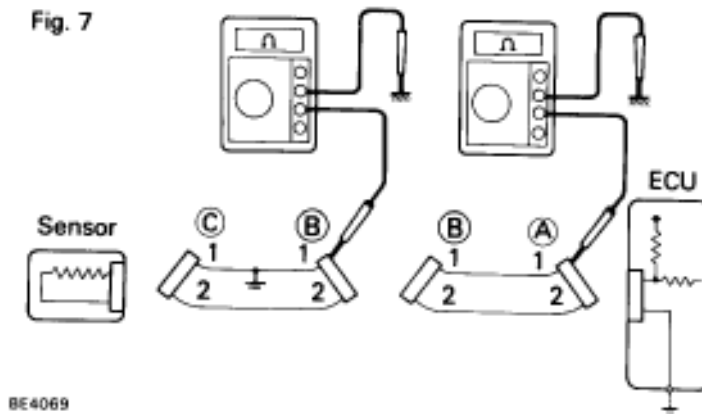

Check and Replace ECU

First check the ECU ground circuit. If it is faulty, repair it. If it is normal, the ECU could be faulty, so replace the ECU with a known good one and check if the symptoms appear.

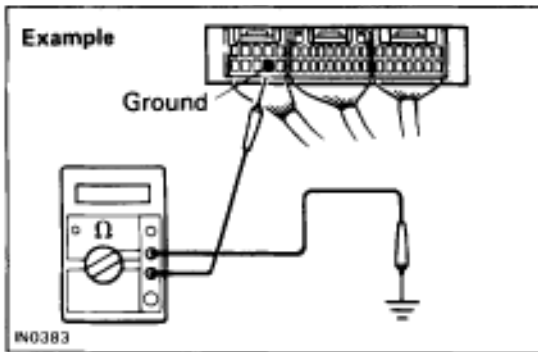

- (1) Measure the resistance between the ECU ground terminal and the body ground.

Resistance: 1 Ω or less

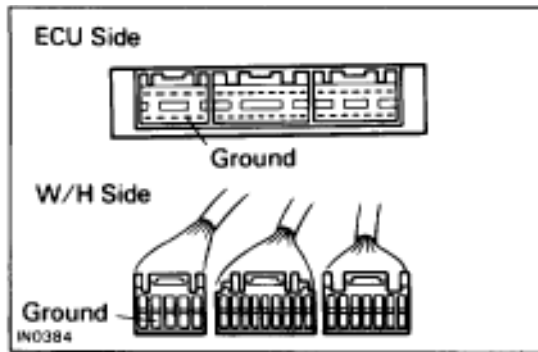

- (2) Disconnect the ECU connector, check the ground terminals on the ECU side and wire harness side for bend and check the contact pressure.

VEHICLE LIFT AND SUPPORT LOCATIONS

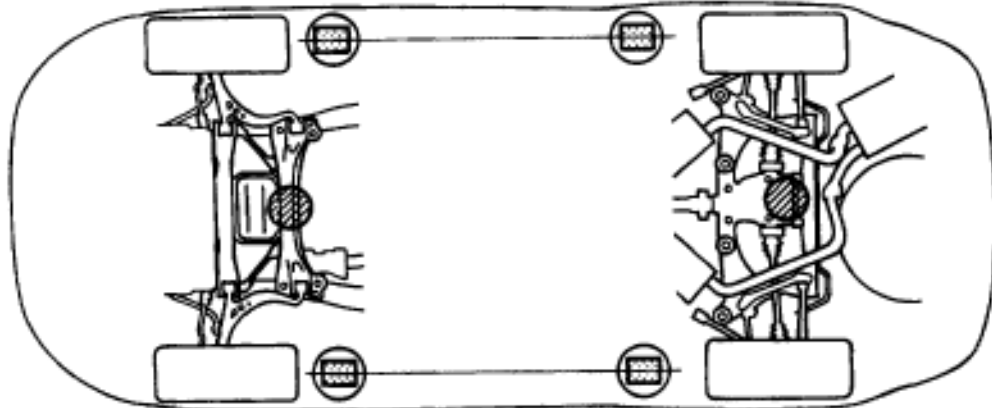

← Front

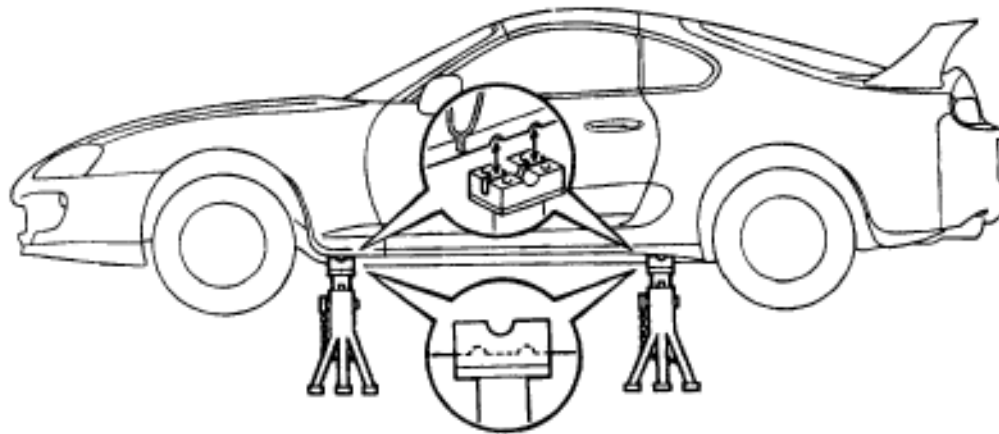

JACK POSITION _____ ●

Front..... Front crossmember

Rear..... Rear axle beam

CAUTION: Before jacking-up the rear and front, make sure the car is not carrying any extra weight.

PANTOGRAPH JACK POSITION _____ ○

SUPPORT POSITION

Safety stand and swing arm type lift ▣

ABBREVIATIONS USED IN THIS MANUAL

ABS	Anti-Lock Brake System
ALR	Automatic Locking Retractor
APPROX.	Approximately
A/T, ATM	Automatic Transmission
ATF	Automatic Transmission Fluid
BTDC	Before Top Dead Center
CB	Circuit Breaker
CD	Compact Disc
CRS	Child Restraint System
DOHC	Double Over Head Cam
DP	Dash Pot
ECU	Electronic Control Unit
ELR	Emergency Locking Retractor
ESA	Electronic Spark Advance
ETR	Electronic Turning Radio
EX	Exhaust
FIPG	Formed in Place Gasket
FL	Fusible Link
Fr	Front
H-Fuse	High Current Fuse
IG	Ignition
IN	Intake
JB	Junction Block
LED	Light Emitting Diode
LH	Left-Hand
LSD	Limited Slip Differential
Max.	Maximum
MP	Multipurpose
M/T	Manual Transmission
O/D	Overdrive
O/S	Oversize
P & BV	Proportioning and By-pass Valve
PCV	Positive Crankcase Ventilation
PPS	Progressive Power Steering
PS	Power Steering

RH	Right-Hand
SRS	Supplemental Restraint System
SSM	Special Service Materials
SST	Special Service Tools
STD	Standard
SW	Switch
TEMP.	Temperature
TRAC	Traction Control System
U/S	Undersize
VSV	Vacuum Switching Valve
w/	With
w/o	Without

GLOSSARY OF SAE AND TOYOTA TERMS

This glossary lists all SAE-J1930 terms and abbreviations used in this manual in compliance with SAE recommendations, as well as their Toyota equivalents.









SAE ABBREVIATIONS	SAE TERMS	TOYOTA TERMS () — ABBREVIATIONS
A/C	Air Conditioning	Air Conditioner
ACL	Air Cleaner	Air Cleaner
AIR	Secondary Air Injection	Air Injection (AI)
AP	Accelerator Pedal	—
B+	Battery Positive Voltage	+B, Battery Voltage
BARO	Barometric Pressure	—
CAC	Charge Air Cooler	Intercooler
CARB	Carburetor	Carburetor
CFI	Continuous Fuel Injection	—
CKP	Crankshaft Position	Crank Angle
CL	Closed Loop	Closed Loop
CMP	Camshaft Position	Cam Angle
CPP	Clutch Pedal Position	—
CTOX	Continuous Trap Oxidizer	—
CTP	Closed Throttle Position	Idle ON (IDL ON)
DFI	Direct Fuel Injection (Diesel)	Direct Injection (DI)
DI	Distributor Ignition	—
DLC1	Data Link Connector 1	1: Check Connector
DLC2	Data Link Connector 2	2: Toyota Diagnosis Communication Link (TDCL)
DLC3	Data Link Connector 3	3: OBD II Diagnostic Connector
DTC	Diagnostic Trouble Code	Diagnostic Code
DTM	Diagnostic Test Mode	—
ECL	Engine Control Level	—
ECM	Engine Control Module	Engine ECU (Electronic Control Unit)
ECT	Engine Coolant Temperature	Coolant Temperature, Water Temperature (THW)
EEPROM	Electrically Erasable Programmable Read Only Memory	Electrically Erasable Programmable Read Only Memory (EEPROM), Erasable Programmable Read Only Memory (EPROM)
EFE	Early Fuel Evaporation	Cold Mixture Heater (CMH), Heat Control Valve (HCV)
EGR	Exhaust Gas Recirculation	Exhaust Gas Recirculation (EGR)
EI	Electronic Ignition	Toyota Distributorless Ignition (TDI)
EM	Engine Modification	Engine Modification (EM)
EPROM	Erasable Programmable Read Only Memory	Programmable Read Only Memory (PROM)
EVAP	Evaporative Emission	Evaporative Emission Control (EVAP)
FC	Fan Control	—
FEEPROM	Flash Electrically Erasable Programmable Read Only Memory	—
FEPROM	Flash Erasable Programmable Read Only Memory	—
FF	Flexible Fuel	—
FP	Fuel Pump	Fuel Pump
GEN	Generator	Alternator
GND	Ground	Ground (GND)
HO2S	Heated Oxygen Sensor	Heated Oxygen Sensor (HO2S)

IAC	Idle Air Control	Idle Speed Control (ISC)
IAT	Intake Air Temperature	Intake or Inlet Air Temperature
ICM	Ignition Control Module	–
IFI	Indirect Fuel Injection	Indirect Injection
IFS	Inertia Fuel-Shutoff	–
ISC	Idle Speed Control	–
KS	Knock Sensor	Knock Sensor
MAF	Mass Air Flow	Air Flow Meter
MAP	Manifold Absolute Pressure	Manifold Pressure Intake Vacuum
MC	Mixture Control	Electric Bleed Air Control Valve (EBCV) Mixture Control Valve (MCV) Electric Air Control Valve (EACV)
MDP	Manifold Differential Pressure	–
MFI	Multiport Fuel Injection	Electronic Fuel Injection (EFI)
MIL	Malfunction Indicator Lamp	Check Engine Light
MST	Manifold Surface Temperature	–
MVZ	Manifold Vacuum Zone	–
NVRAM	Non-Volatile Random Access Memory	–
O ₂ S	Oxygen Sensor	Oxygen Sensor, O ₂ Sensor (O ₂ S)
OBD	On-Board Diagnostic	On-Board Diagnostic (OBD)
OC	Oxidation Catalytic Converter	Oxidation Catalyst Converter (OC), CCo
OP	Open Loop	Open Loop
PAIR	Pulsed Secondary Air Injection	Air Suction (AS)
PCM	Powertrain Control Module	–
PNP	Park/Neutral Position	–
PROM	Programmable Read Only Memory	–
PSP	Power Steering Pressure	–
PTOX	Periodic Trap Oxidizer	Diesel Particulate Filter (DPF) Diesel Particulate Trap (DPT)
RAM	Random Access Memory	Random Access Memory (RAM)
RM	Relay Module	–
ROM	Read Only Memory	Read Only Memory (ROM)
RPM	Engine Speed	Engine Speed
SC	Supercharger	Supercharger
SCB	Supercharger Bypass	–
SFI	Sequential Multiport Fuel Injection	Electronic Fuel Injection (EFI), Sequential Injection
SPL	Smoke Puff Limiter	–
SRI	Service Reminder Indicator	–
SRT	System Readiness Test	–
ST	Scan Tool	–
TB	Throttle Body	Throttle Body
TBI	Throttle Body Fuel Injection	Single Point Injection Central Fuel Injection (Ci)
TC	Turbocharger	Turbocharger
TCC	Torque Converter Clutch	Torque Converter
TCM	Transmission Control Module	Transmission ECU (Electronic Control Unit)
TP	Throttle Position	Throttle Position
TR	Transmission Range	–

TVV	Thermal Vacuum Valve	Bimetallic Vacuum Switching Valve (BVSV) Thermostatic Vacuum Switching Valve (TVSV)
TWC	Three-Way Catalytic Converter	Three-Way Catalytic (TWC) CC _{RO}
TWC+OC	Three-Way + Oxidation Catalytic Converter	CC _R + CC _o
VAF	Volume Air Flow	Air Flow Meter
VR	Voltage Regulator	Voltage Regulator
VSS	Vehicle Speed Sensor	Vehicle Speed Sensor (Read Switch Type)
WOT	Wide Open Throttle	Full Throttle
WU-OC	Warm Up Oxidation Catalytic Converter	–
WU-TWC	Warm Up Three-Way Catalytic Converter	Manifold Converter
3GR	Third Gear	–
4GR	Fourth Gear	–

STANDARD BOLT TORQUE SPECIFICATIONS

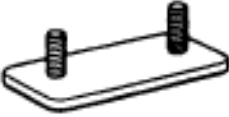
HOW TO DETERMINE BOLT STRENGTH

	Mark	Class		Mark	Class
Hexagon head bolt	 <p>Bolt head No.</p> <p>4— 4T 5— 5T 6— 6T 7— 7T 8— 8T 9— 9T 10— 10T 11— 11T</p>		Stud bolt	 <p>No mark</p> <p>4T</p>	
	 <p>No mark</p> <p>4T</p>				
Hexagon flange bolt w/ washer hexagon bolt	 <p>No mark</p> <p>4T</p>		Welded bolt	 <p>Grooved</p> <p>6T</p>	
Hexagon head bolt	 <p>2 protruding lines</p> <p>5T</p>				
Hexagon flange bolt w/ washer hexagon bolt	 <p>2 protruding lines</p> <p>6T</p>		Welded bolt	 <p>4T</p>	
Hexagon head bolt	 <p>3 protruding lines</p> <p>7T</p>				
Hexagon head bolt	 <p>4 protruding lines</p> <p>8T</p>				

SPECIFIED TORQUE FOR STANDARD BOLTS

Class	Diameter Mm	Pitch mm	Specified torque					
			Hexagon head bolt			Hexagon flange bolt		
			N·m	kgf·cm	ft·lbf	N·m	kgf·cm	ft·lbf
4T	6	1	5	55	48 in.·lbf	6	60	52 in.·lbf
	8	1.25	12.5	130	9	14	145	10
	10	1.25	26	260	19	29	290	21
	12	1.25	47	480	35	53	540	39
	14	1.5	74	760	55	84	850	61
	16	1.5	115	1,150	83	–	–	–
5T	6	1	6.5	65	56 in.·lbf	7.5	75	65 in.·lbf
	8	1.25	15.5	160	12	17.5	175	13
	10	1.25	32	330	24	36	360	26
	12	1.25	59	600	43	65	670	48
	14	1.5	91	930	67	100	1,050	76
	16	1.5	140	1,400	101	–	–	–
6T	6	1	8	80	69 in.·lbf	9	90	78 in.·lbf
	8	1.25	19	195	14	21	210	15
	10	1.25	39	400	29	44	440	32
	12	1.25	71	730	53	80	810	59
	14	1.5	110	1,100	80	125	1,250	90
	16	1.5	170	1,750	127	–	–	–
7T	6	1	10.5	110	8	12	120	9
	8	1.25	25	260	19	28	290	21
	10	1.25	52	530	38	58	590	43
	12	1.25	95	970	70	105	1,050	76
	14	1.5	145	1,500	108	165	1,700	123
	16	1.5	230	2,300	166	–	–	–
8T	8	1.25	29	300	22	33	330	24
	10	1.25	61	620	45	68	690	50
	12	1.25	110	1,100	80	120	1,250	90
9T	8	1.25	34	340	25	37	380	27
	10	1.25	70	710	51	78	790	57
	12	1.25	125	1,300	94	140	1,450	105
10T	8	1.25	38	390	28	42	430	31
	10	1.25	78	800	58	88	890	64
	12	1.25	140	1,450	105	155	1,600	116
11T	8	1.25	42	430	31	47	480	35
	10	1.25	87	890	64	97	990	72
	12	1.25	155	1,600	116	175	1,800	130